

Ceramic backings and their applications



Ceramic backings and their applications

Ceramic backings are made of sealed, high temperature resistant ceramic, from different mineral mixes (e.g. Al_2O_3 , SiO_2 , Fe_2O_3 , TiO_2). When they melt, they produce a glassy slag that forms the underside of the weld seam and seals it against air entering. They are chemically neutral in the weld pool. Ceramic backings are available as ceramic blocks (~2 cm long) on a flexible aluminum foil with an adhesive edge, that can be stuck to the underside of the weld seam. They are also available as single ceramic segments (~10 to 15 cm long) for placement in metallic rails that are then attached to the work piece with magnets or other fixtures.

The ceramic backings offer special economic advantages for submerged arc welding and MAG welding with solid wires or metal-cored wires in the downhand position as well for positional MAG welding using rutile cored wires with fast freezing slag.

Examples of ceramic backing applications

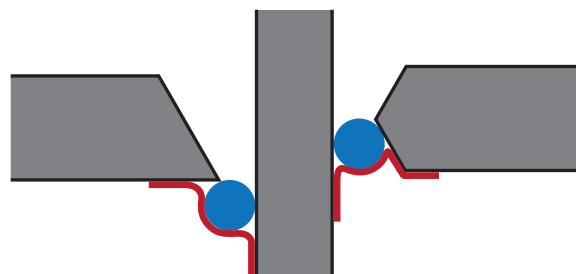
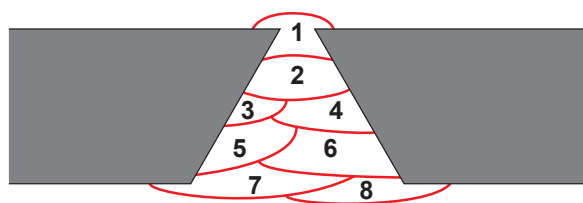
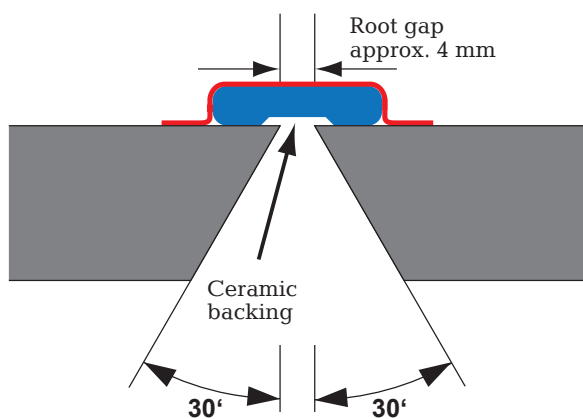



Ceramic backings are traditionally used in industry segments that are under pressure to keep costs low, such as shipbuilding. However, today they are increasingly used in pressure vessel fabrication, machine construction, general steel construction, tanks, bridges and plant engineering.

Application tips:

- Ideal for mechanized, one-sided welding with high currents and for manual welding of root runs with increased welding parameters (MAG solid wire and MAG cored wire).
- Root runs can be produced in thicknesses that make it possible to weld filler layers (as from the second layer) with very high currents and deposition rate, without the risk of burn-through.
- Suitable for compensating deviations in fit-up, without the need to significantly adjust the welding parameters, thereby ensuring a high quality root. Irregular root gaps can be welded without time-consuming adjustments.
- In two-sided welding, expensive back grinding can usually be completely eliminated.
- Root runs welded with ceramic backing normally have a lower incidence of insufficient penetration, undercut, pores, slag inclusions and restart errors.
- One-sided welding with ceramic backing increases process reliability when root runs have to be notch-free, e.g. in the case of dynamic loading or stress corrosion.
- Due to their moisture resistance, ceramic backings are also suitable for outdoor welding. One-sided welding at the construction site can often be carried out on the inside of the component so that weather conditions do not play a role.
- Dense ceramics with low moisture content are ideal for welding high-strength, fine-grained steels that require weld metals with very low hydrogen content.

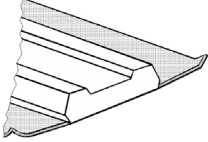
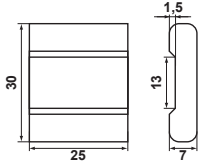
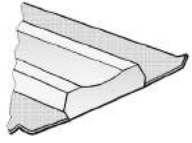
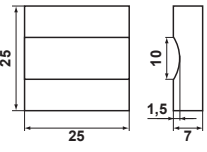
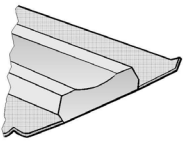
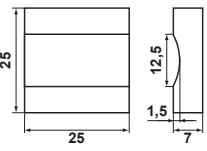
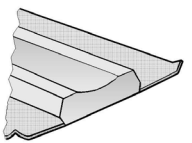
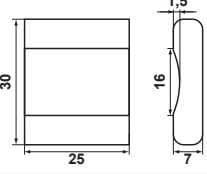
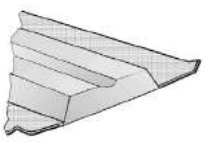
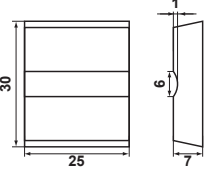
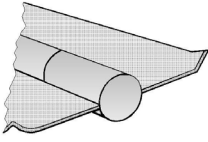
The most commonly used ceramic backings; other types on request

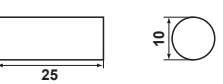
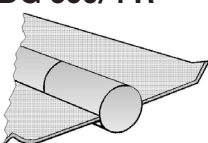
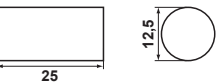
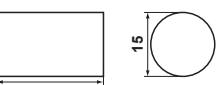
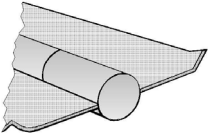
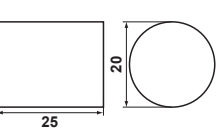
Type	Dimensions	Description	Length	Part-No.	Packaging Unit
AG 600/5 R 		Ceramic with trapezoidal groove for butt welds and V-welds; attached with self-adhesive aluminum strip	600 mm	71325	42 Stck / Box 25,2 m / Box
BG 600/1 R 		Ceramic with round groove for butt welds and V-welds; attached with self-adhesive aluminum strip	600 mm	71111	42 Stck / Box 25,2 m / Box
BG 600/2 R 		Ceramic with round groove for butt welds and V-welds; attached with self-adhesive aluminum strip	600 mm	70893 on request	42 Stck / Box 25,2 m / Box
BG 600/4 R 		Ceramic with round groove for butt welds and V-welds; attached with self-adhesive aluminum strip	600 mm	70149 on request	42 Stck / Box 25,2 m / Box
BG 600/8 R 		Ceramic with round groove for butt welds and V-welds; attached with self-adhesive aluminum strip	600 mm	71110 on request	42 Stck / Box 25,2 m / Box
DG 600/1 R DG 600/2 R 	 	Ceramic with cylindrical shape for X-welds and fillet welds; attached with self-adhesive aluminum strip	600 mm	DG 600/1 R 70220	100 Stck / Box 60 m / Box
		DG 600/1 R = 20mm/6mm DG 600/2 R = 25mm/10mm		DG 600/2 R 70221	72 Stck / Box 43.2 m / Box
DG 600/3 R DG 600/4 R 	 	Ceramic with cylindrical shape for X-welds and fillet welds; attached with self-adhesive aluminum strip	600 mm	DG 600/3 R 70222	60 Stck / Box 36 m / Box
		DG 600/3 R = 25mm/12mm DG 600/4 R = 25mm/15mm		DG 600/4 R 70223 on request	36 Stck / Box 21.6 m / Box
DG 600/5 R 		Ceramic with cylindrical shape for X-welds and fillet welds; attached with self-adhesive aluminum strip	600 mm	71109 on request	27 Stck / Box 16.2 m / Box

10.04 Ceramic backings

| Date: 2014-06-30

This information is an aid for practitioners. It provides a simplified version of fundamental technical facts and does not claim to be complete.
A guarantee of the suitability for a specific application requires an express written agreement in each case

Art / Product

Keramik auf selbstklebenden Aluminiumband mit trapezförmiger Nut.
Farbgebung: grau

Ceramic on self-adhesive aluminium tape with trapezoidal form groove.
Coloration: grey

Abmessung / Dimension

Länge / Length	Nutbreite / Groove width	Nuttiefe / Groove depth	Teilung / Segment size
600 mm	13 mm	1,5 mm	30 x 25 mm

Artikelnummer / Article No.

71325

Verpackungseinheiten / Packing

Karton / Carton		Palette / Pallet	
Stück / Piece	Meter / Meter	Karton / Carton	Stück / Piece
42	25,2	45	1890

Abmessung / Dimension

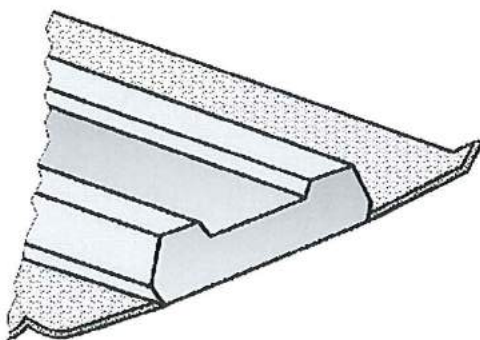
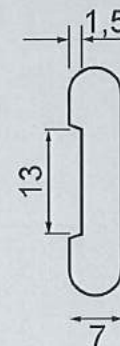
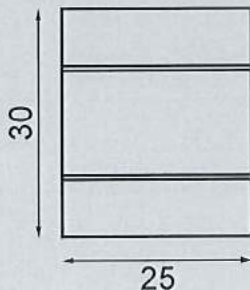

Art / Product

Keramik auf selbstklebenden Aluminiumband mit halbrunder Nut.
Farbgebung: grau

Ceramic on self-adhesive aluminium tape with half-circle groove.
Coloration: grey

Abmessung / Dimension

Länge / Length	Nutbreite / Groove width	Nuttiefe / Groove depth	Teilung / Segment size
600 mm	10 mm	1,5 mm	25 x 25 mm

Artikelnummer / Article No.

71111

Verpackungseinheiten / Packing

Karton / Carton		Palette / Pallet	
Stück / Piece	Meter / Meter	Karton / Carton	Stück / Piece
42	25,2	45	1890

Abmessung / Dimension

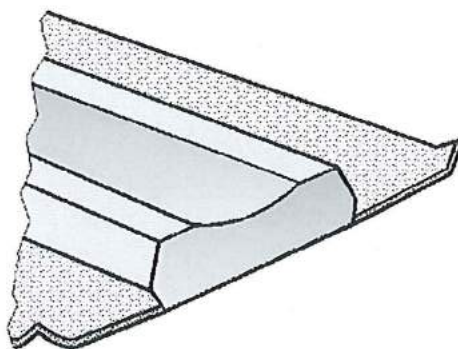
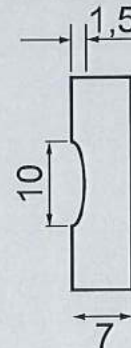
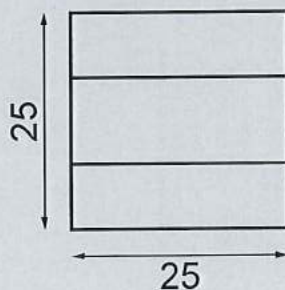

Art / Product

Keramik auf selbstklebenden Aluminiumband mit halbrunder Nut.
Farbgebung: grau

Ceramic on self-adhesive aluminium tape with half-circle groove.
Coloration: grey

Abmessung / Dimension

Länge / Length	Nutbreite / Groove width	Nuttiefe / Groove depth	Teilung / Segment size
600 mm	12,5 mm	1,5 mm	25 x 25 mm

Artikelnummer / Article No.

70893

Verpackungseinheiten / Packing

Karton / Carton		Palette / Pallet	
Stück / Piece	Meter / Meter	Karton / Carton	Stück / Piece
42	25,2	45	1890

Abmessung / Dimension

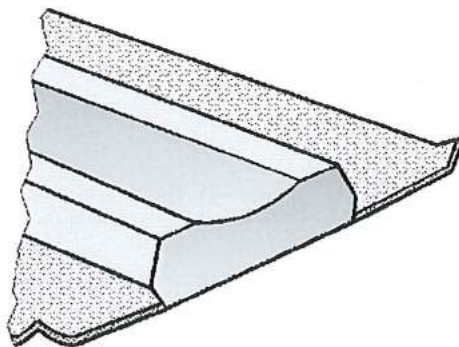
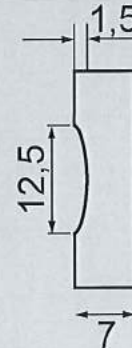
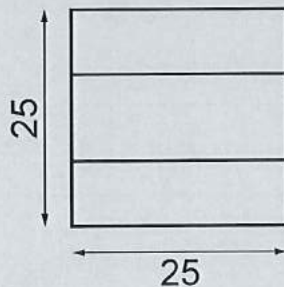

Art / Product

Keramik auf selbstklebenden Aluminiumband mit halbrunder Nut.
Farbgebung: grau

Ceramic on self-adhesive aluminium tape with half-circle groove.
Coloration: grey

Abmessung / Dimension

Länge / Length	Nutbreite / Groove width	Nuttiefe / Groove depth	Teilung / Segment size
600 mm	16 mm	1,5 mm	30 x 25 mm

Artikelnummer / Article No.

70149

Verpackungseinheiten / Packing

Karton / Carton		Palette / Pallet	
Stück / Piece	Meter / Meter	Karton / Carton	Stück / Piece
42	25,2	45	1890

Abmessung / Dimension

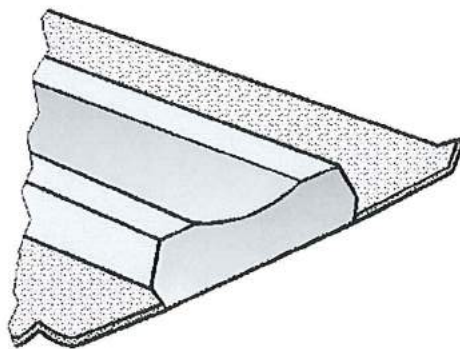
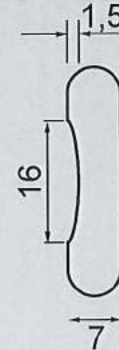
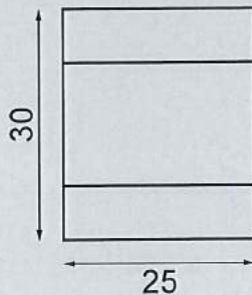

Art / Product

Keramik auf selbstklebenden Aluminiumband mit halbrunder Nut.

Farbgebung: grau

Ceramic on self-adhesive aluminium tape with half-circle groove.

Coloration: grey

Abmessung / Dimension

Länge / Length	Nutbreite / Groove width	Nuttiefe / Groove depth	Teilung / Segment size
600 mm	6 mm	1,0 mm	25 x 20 mm

Artikelnummer / Article No.

71110

Verpackungseinheiten / Packing

Karton / Carton		Palette / Pallet	
Stück / Piece	Meter / Meter	Karton / Carton	Stück / Piece
42	25,2	45	1890

Abmessung / Dimension

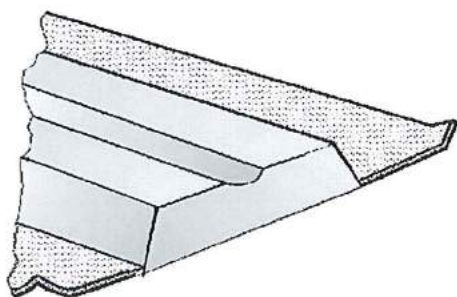
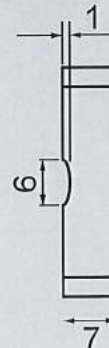
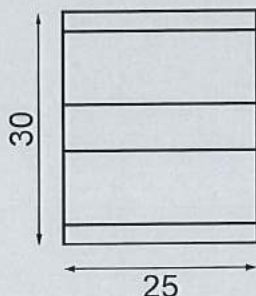

Art / Product

Keramik auf selbstklebenden Aluminiumband zylindrische Form.
Farbgebung: grau

Ceramic on self-adhesive aluminium tape cylindrical shape.
Coloration: grey

Abmessung / Dimension

Länge / Length	Durchmesser / Diameter	Teilung / Segment size
600 mm	6,0 mm	20 mm

Artikelnummer / Article No.

70220

Verpackungseinheiten / Packing

Karton / Carton		Palette / Pallet	
Stück / Piece	Meter / Meter	Karton / Carton	Stück / Piece
100	60	45	4500

Abmessung / Dimension

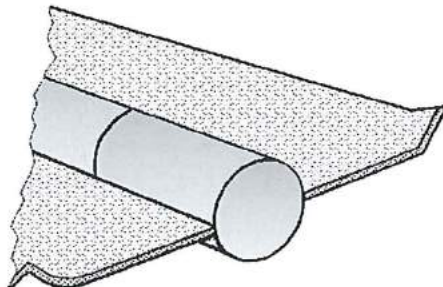
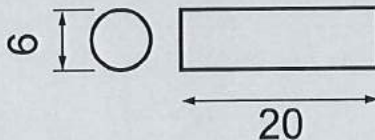

Art / Product

Keramik auf selbstklebenden Aluminiumband zylindrische Form.

Farbgebung: grau

Ceramic on self-adhesive aluminium tape cylindrical shape.

Coloration: grey

Abmessung / Dimension

Länge / Length	Durchmesser / Diameter	Teilung / Segment size
600 mm	10,0 mm	25 mm

Artikelnummer / Article No.

70221

Verpackungseinheiten / Packing

Karton / Carton		Palette / Pallet	
Stück / Piece	Meter / Meter	Karton / Carton	Stück / Piece
72	43,2	45	3240

Abmessung / Dimension

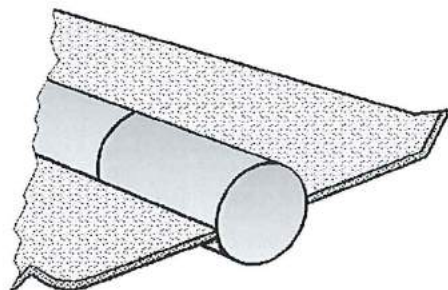
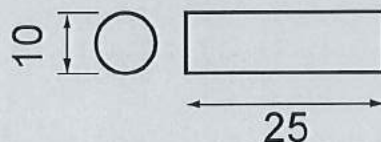

Art / Product

Keramik auf selbstklebenden Aluminiumband zylindrische Form.

Farbgebung: grau

Ceramic on self-adhesive aluminium tape cylindrical shape.

Coloration: grey

Abmessung / Dimension

Länge / Length	Durchmesser / Diameter	Teilung / Segment size
600 mm	12,0 mm	25 mm

Artikelnummer / Article No.

70222

Verpackungseinheiten / Packing

Karton / Carton		Palette / Pallet	
Stück / Piece	Meter / Meter	Karton / Carton	Stück / Piece
60	36	45	2700

Abmessung / Dimension

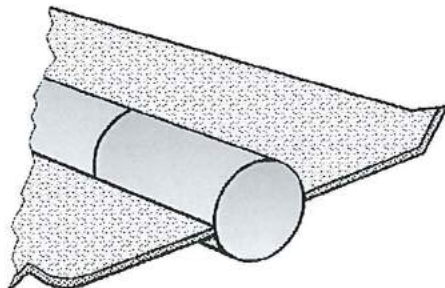
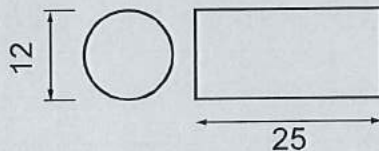

Art / Product

Keramik auf selbstklebenden Aluminiumband zylindrische Form.

Farbgebung: grau

Ceramic on self-adhesive aluminium tape cylindrical shape.

Coloration: grey

Abmessung / Dimension

Länge / Length	Durchmesser / Diameter	Teilung / Segment size
600 mm	15,0 mm	25 mm

Artikelnummer / Article No.

70223

Verpackungseinheiten / Packing

Karton / Carton		Palette / Pallet	
Stück / Piece	Meter / Meter	Karton / Carton	Stück / Piece
36	21,6	45	1620

Abmessung / Dimension

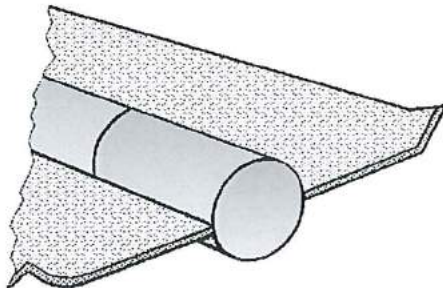
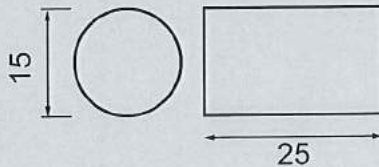

Art / Product

Keramik auf selbstklebenden Aluminiumband zylindrische Form.

Farbgebung: grau

Ceramic on self-adhesive aluminium tape cylindrical shape.

Coloration: grey

Abmessung / Dimension

Länge / Length	Durchmesser / Diameter	Teilung / Segment size
600 mm	20 mm	25 mm

Artikelnummer / Article No.

71109

Verpackungseinheiten / Packing

Karton / Carton		Palette / Pallet	
Stück / Piece	Meter / Meter	Karton / Carton	Stück / Piece
27	16,2	45	1215

Abmessung / Dimension

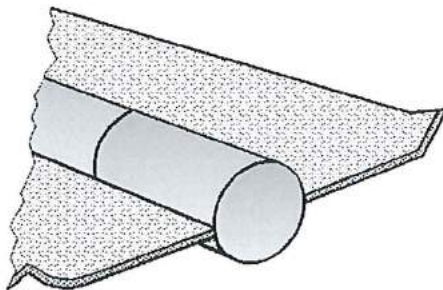
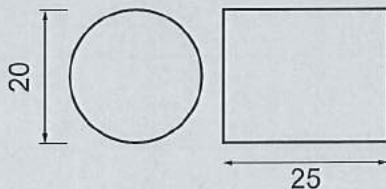

voestalpine Böhler Welding

Welding know-how joins steel

Customers in over 120 countries join the expertise of voestalpine Böhler Welding. Focused on filler metals, voestalpine Böhler Welding offers extensive technical consultation and individual solutions for industrial welding and soldering applications. Customer proximity is guaranteed by 40 subsidiaries in 28 countries, with the support of 2,200 employees, and through more than 1,000 distribution partners worldwide. voestalpine Böhler Welding offers three specialized and dedicated brands to cater our customers' and partners' requirements.



Böhler Welding – More than 2,000 products for joint welding in all conventional arc welding processes are united in a product portfolio that is unique throughout the world. Creating lasting connections is the brand's philosophy in welding and between people.



UTP Maintenance – Decades of industry experience and application know-how in the areas of repair as well as wear and surface protection, combined with innovative and custom-tailored products, guarantee customers an increase in the productivity and protection of their components.



Fontargen Brazing – Through deep insight into processing methods and ways of application, Fontargen Brazing provides the best brazing and soldering solutions based on proven products with German technology. The expertise of this brand's application engineers has been formulated over many years of experience from countless application cases.

forwarded by:

Böhler Welding

Global Brand Management

bohler.welding@voestalpine.com

www.boehler-welding.com

voestalpine Böhler Welding

www.voestalpine.com/welding

voestalpine

ONE STEP AHEAD.