



Lasting Connections

# Filler Material and Automation Solutions Now from One Trusted Source



voestalpine Böhler Welding Automation  
[www.voestalpine.com/welding](http://www.voestalpine.com/welding)

**voestalpine**

ONE STEP AHEAD.



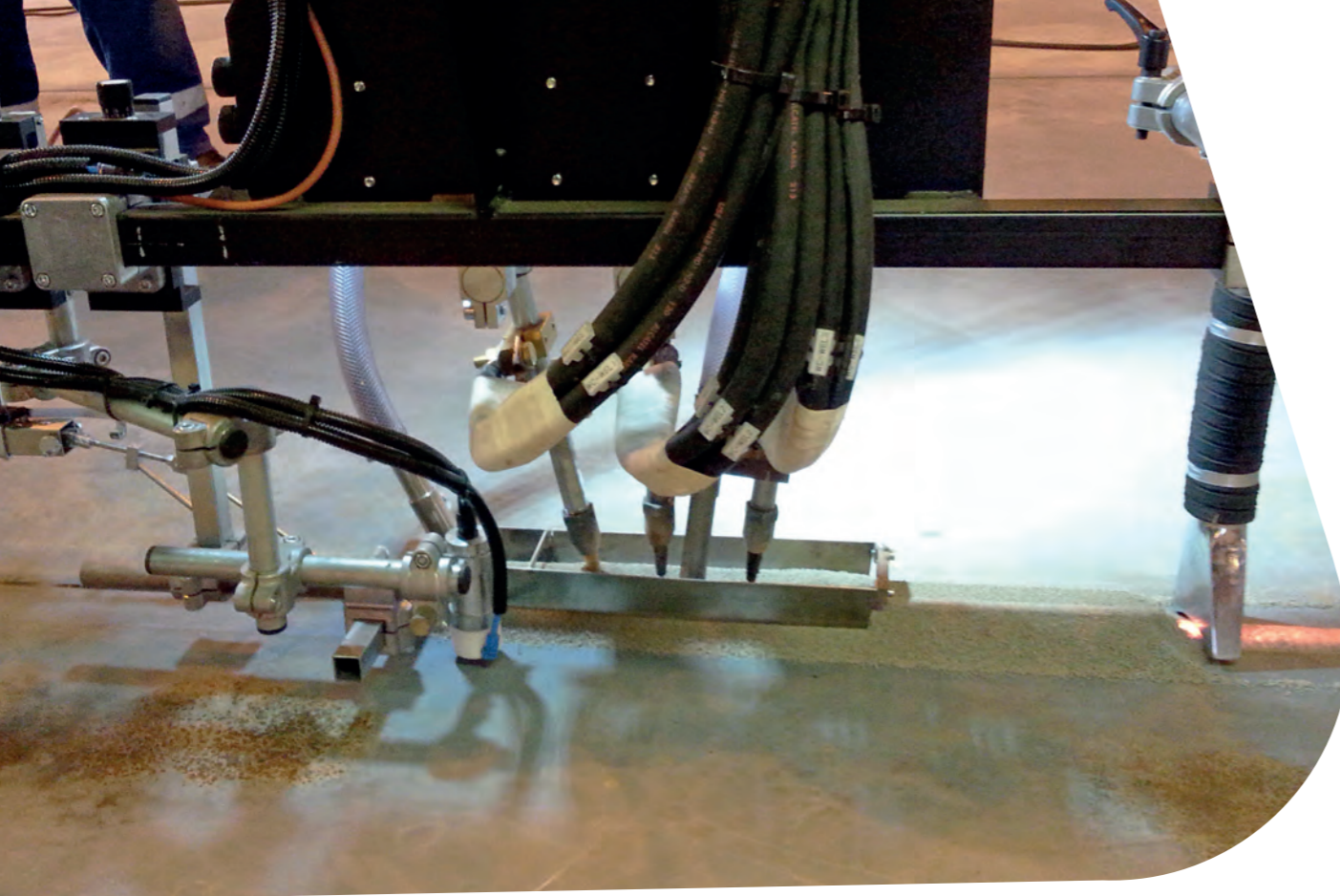

## Automation Combines with Process Know-how

Unique filler material expertise is now available as an integral part of customized submerged arc welding process solutions. Böhler Welding Automation combines it with process know-how covering the following SAW variants:

- Single wire
- Multi-wire
- Twin wire
- Narrow gap
- Tandem wire
- SAW and ESW strip cladding
- Tandem-twin wire

We supply complete solutions for these variants comprising power sources, process controllers, welding heads, seam tracking systems, wire feeding and straightening units, flux feeding and recovery systems, welding portals, positioners and roller beds. Wire and flux is available in standard weight units as well as in bulk packaging for systems with high consumables consumption.

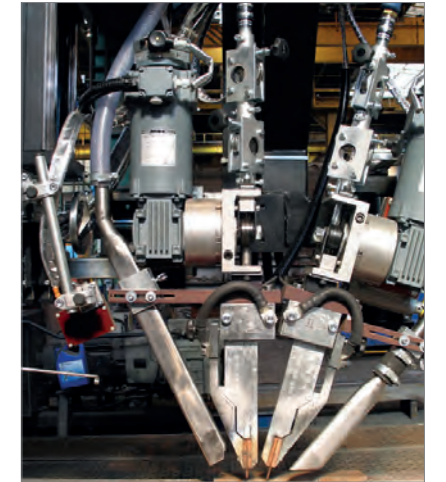

## Filler Material and Automation Solutions Now from One Trusted Source

Joining forces with welding automation specialist WELTRON GmbH, Böhler Welding can now offer full process solutions. Böhler Welding Automation combines unique filler material expertise with welding process competence focusing on multi-wire submerged arc welding. We are capable to deliver turnkey systems based on excellent mechanization know-how and developed with full focus on customer specific technological and economic requirements. Clients are enabled to participate in the development of their arc welding solutions and receive full support and service in making systems operational.



### The Böhler Welding Automation commitment:

- Made in Germany
- Reliable welding technology
- 24 hours service for system availability
- Flexible solutions
- Combined filler material and automation expertise
- Latest safety standards
- CE conform documentation

## Lasting Connections

As a pioneer in welding consumables for the joining of metals, Böhler Welding offers a globally unique and customer-focused portfolio for lasting connections. The extensive range of approximately 2.000 products is continuously aligned with latest industry specifications and customer requirements, certified by leading approval authorities, and thereby accredited for even the most challenging applications.

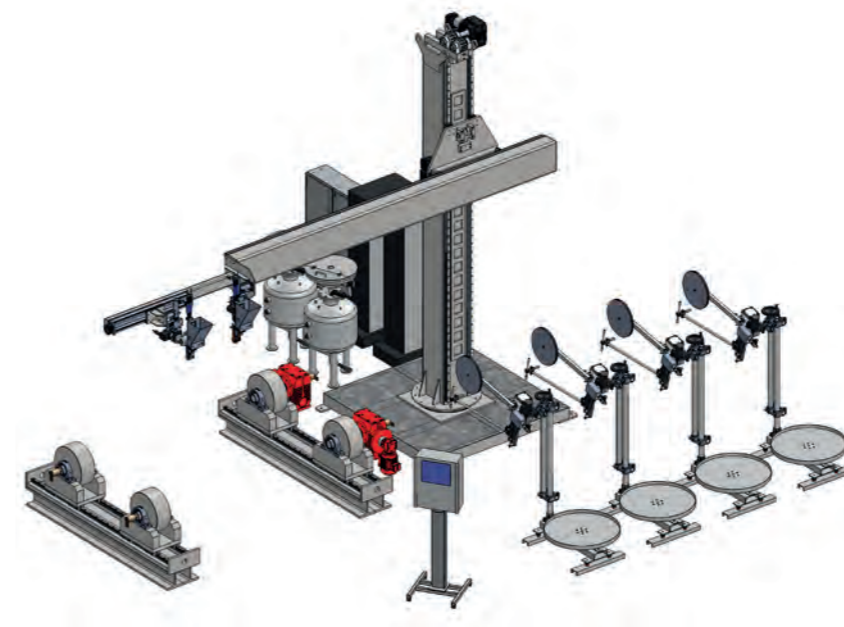



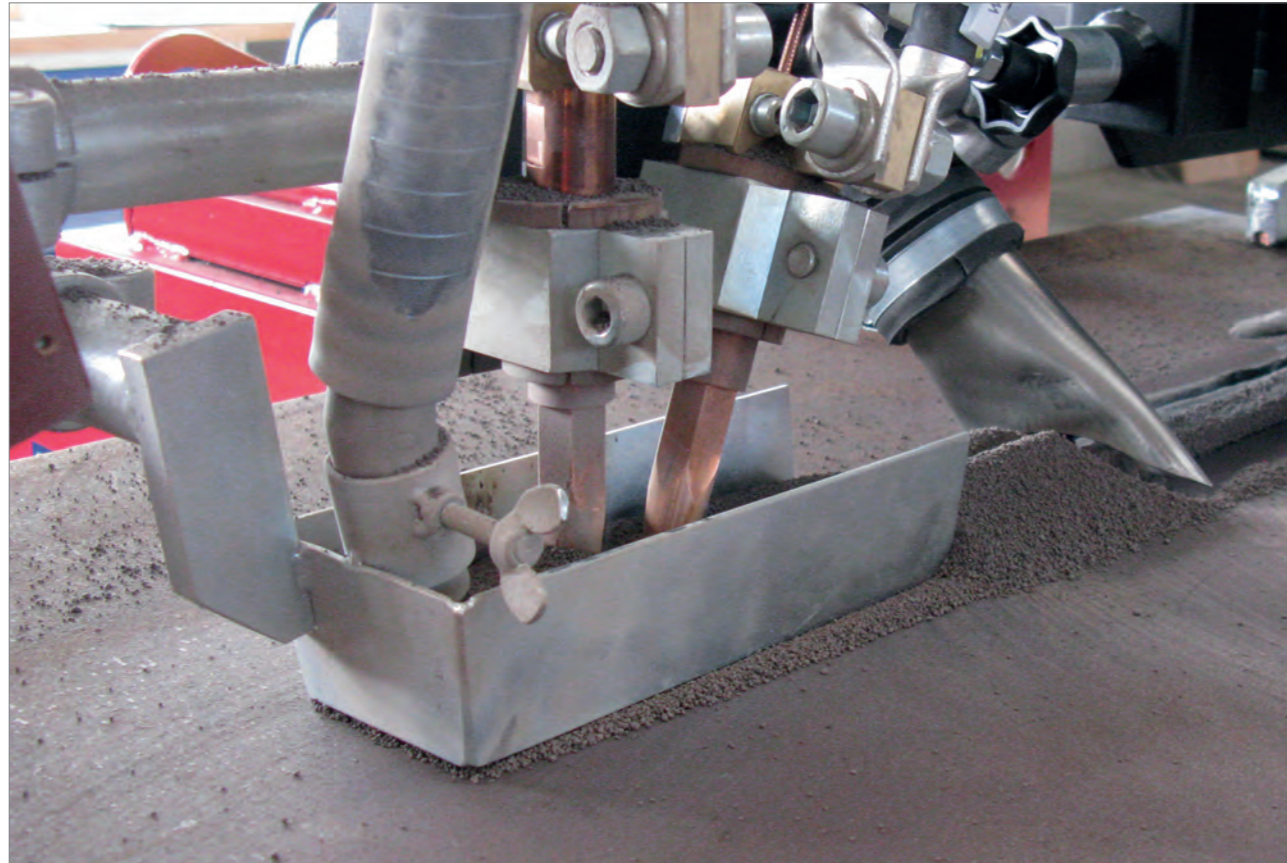

## Tailor-Made Solutions

Optimal solutions in terms of process variants and mechanization concepts are discussed with our customers during the preparation phase of the offer. When accepted, the actual design and construction of the SAW equipment is fully performed in-house, making use of modern 3D-CAD tools. The same is valid for the complete electrical and electronic design, including machine control panels and control cabinets. Also machine/customer specific software – such as PLC programs in Step 7 format, user interfaces in WIN-CC format and interfaces for various Bus systems – are developed in-house with great flexibility. Last but not least, Böhler Welding Automation performs the complete assembly and commissioning of the equipment at the customers' site, at home and abroad.

### The Böhler Welding Automation commitment:

- Return on investment
- Flexible solutions
- Made in Germany
- Latest safety standards
- Reliable welding technology
- CE conform documentation
- 24 hours service for system availability
- Combined filler material and automation expertise

## Submerged Arc Welding Unlimited

Böhler Welding offers over 120 wire/flux combinations for the joining of materials with the submerged arc welding process. They are fully developed and manufactured in-house, covering non-alloyed, weather resistant, high strength, low-temperature and creep resistant steel, all types of stainless steel, as well as nickel-base alloys. All over the world, fabricators in demanding industrial segments successfully use our products, supported by Böhler Welding application specialists.



## Industry 4.0 in Welding Technology

Digitization and internet are gaining more and more importance in welding technology.

Böhler Welding Automation has developed a submerged arc welding system in which the inverter power source, the PLC welding control and the mechanization components communicate, enabling a real-time process analysis which can even be shown on mobile phones and tablets, when desired. Use for quality monitoring will become possible, enabling control of the welding process and early intervention in case of welding errors, to save time and reduce costs.



voestalpine Böhler Welding Automation process monitoring online



Two examples of installation and measurement data

# voestalpine Böhler Welding

## Welding know-how joins steel

With over 100 years of experience, voestalpine Böhler Welding is the global top company for the daily challenges in the areas of joint welding, repair, hardfacing and cladding as well as brazing. Customer proximity is guaranteed by more than 40 subsidiaries in 25 countries, with the support of 2,200 employees, and through more than 1,000 distribution partners worldwide. With individual consultation by our application technicians and welding engineers, we make sure that our customers master the most demanding welding challenges. voestalpine Böhler Welding offers three specialized and dedicated brands to cater our customers' and partners' requirements.



**Lasting Connections** – As a pioneer in innovative welding consumables, Böhler Welding offers a unique product portfolio for joint welding worldwide. More than 2000 products are adapted continuously to the current industry specifications and customer requirements, certified by well-respected institutes and thus approved for the most demanding welding applications. As a reliable partner for customers, “lasting connections” are the brand’s philosophy in terms of both welding and people.



**Tailor-Made Protectivity™** – UTP Maintenance ensures an optimum combination of protection and productivity with innovative and tailor-made solutions. Everything revolves around the customer and their individual requirements. That is expressed in the central performance promise: Tailor-Made Protectivity™.



**In-Depth Know-How** – As a leading manufacturer of soldering and brazing consumables, Fontargen Brazing offers proven solutions based on 50 years of industrial experience, tried and tested processes and methods. This In-Depth Know-How has made Fontargen Brazing an internationally preferred partner for every soldering and brazing task.

